



Sample Test Project

District / Zonal Skill Competitions

Skill- Mechatronics

Category: Manufacturing & Engineering Technology

Table of Contents

A. Preface.....	3
B. Test Project.....	4
C. Marking Scheme	9
D. Infrastructure List	15
E. Instructions for candidates	18
F. Health, Safety, and Environment.....	19

Section - A

A. Preface

Skill Explained:

Mechatronics combines skills in mechanics, pneumatics, hydraulics, electronics, computer technology, and robotics and systems development. The computer technology element covers the programming of PLC's, robots and other handling systems and information technology applications, programmable machine control systems, and technology which enable communication between machines, equipment, and people.

Mechatronics technicians design, build, commission, maintains, repair, and adjust automated industrial equipment, and also program equipment control systems and human machine interfaces.

The more common and visible mechatronics appliances include shop tills (belt and cash register assemblies) and automated bottle machines.

Eligibility Criteria (for IndiaSkills 2018 and WorldSkills 2019):

Competitors born on or after 01 Jan 1994 are only eligible to attend the Competition.

Total Duration: Theory 4-5 hours, Practical -45mins

Section - B

B. Test Project

Objective Questions to check the basic knowledge in

40 Marks

- Basic Pneumatics
- Electro Pneumatics
- PLC logics

Practical Questions

3 X 20 = 60 Marks

Task-1: Basic Pneumatic

Task -2: Electro Pneumatic

Task-3: PLC Logic

Theoretical Questions

1. Identify the each of the logic (AND, OR, NOT etc) and also complete the logic table.

9 X 2 = 18 Marks

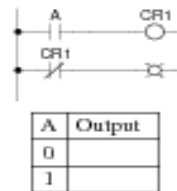
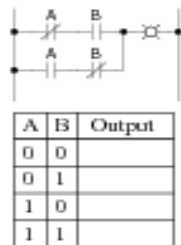
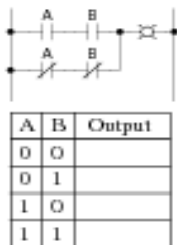
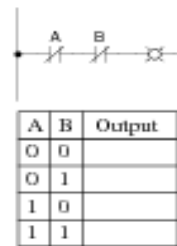
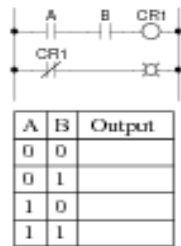
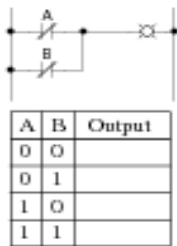
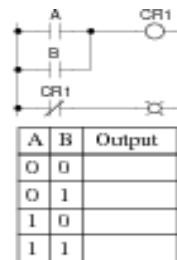
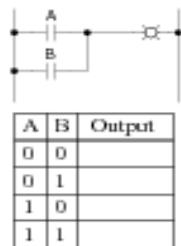
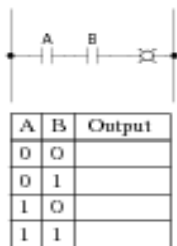

2. Which of the statements are true relating to Pneumatic system?

1 Mark

- Pneumatic drives can take the place of human muscle power.
- Hydraulic or electrical drives are always preferable to pneumatic drives.
- Pneumatic drives only make sense where electrical power is not available.
- Pneumatic drives are not suitable for fast working speeds.

3. An inexperienced user seals the exhaust outlet of the single acting cylinder, to make it leak proof. What will happen if the piston is pressurized with the compressed air?

1 Mark

- The cylinder explodes.
- The piston rod does not move.
- The cylinder operates normally.
- The piston rod advances more slowly and stops too soon.

4. Complete the circuit symbol of the pneumatic semi rotary vane cylinder by filling the correct parts.

1 Mark

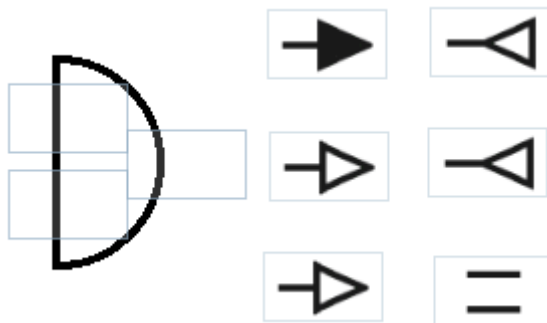

4. Choose the circuit symbol of pneumatic vane motor with unidirectional rotation. 1 Mark

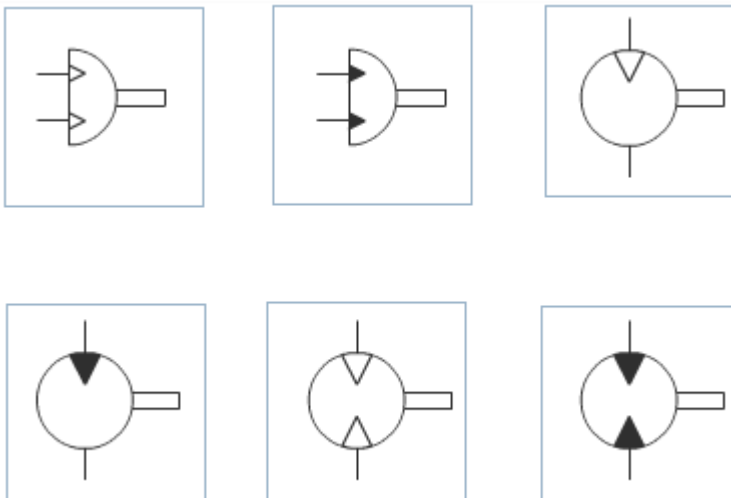

5. Name the ports of the 5/2-way direction control valve as per ISO 1219 standards.

1 Mark

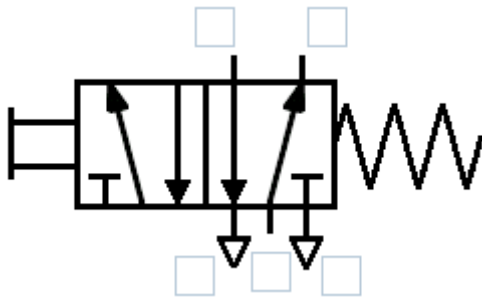

6. Draw the pneumatic symbols for the following.

5 x 2 = 10 marks

3/2 way NC push button operated with spring return DCV	
5/2 way double sided pilot operated DCV	
Two Pressure valve	
Shuttle valve	

One -way flow control valve	
-----------------------------	--

7. From the below table choose the appropriate association between the push button and cylinder. 2 Marks

Description	0	1	2	3
		Press S1		Release S1
A1	1 0			

Highlight all applicable statements! (2)

- The cylinder advances automatically as soon as a workpiece is in the magazine.
- Actuation of the pushbutton causes a workpiece to be ejected from the magazine.
- The cylinder is to retract again by actuating a second pushbutton.
- The cylinder retracts again having reached the forward end position.
- The cylinder retracts again if the pushbutton is released.

8. Complete the circuit by placing the appropriate circuit symbols to make the cylinder to operate. 5 Marks

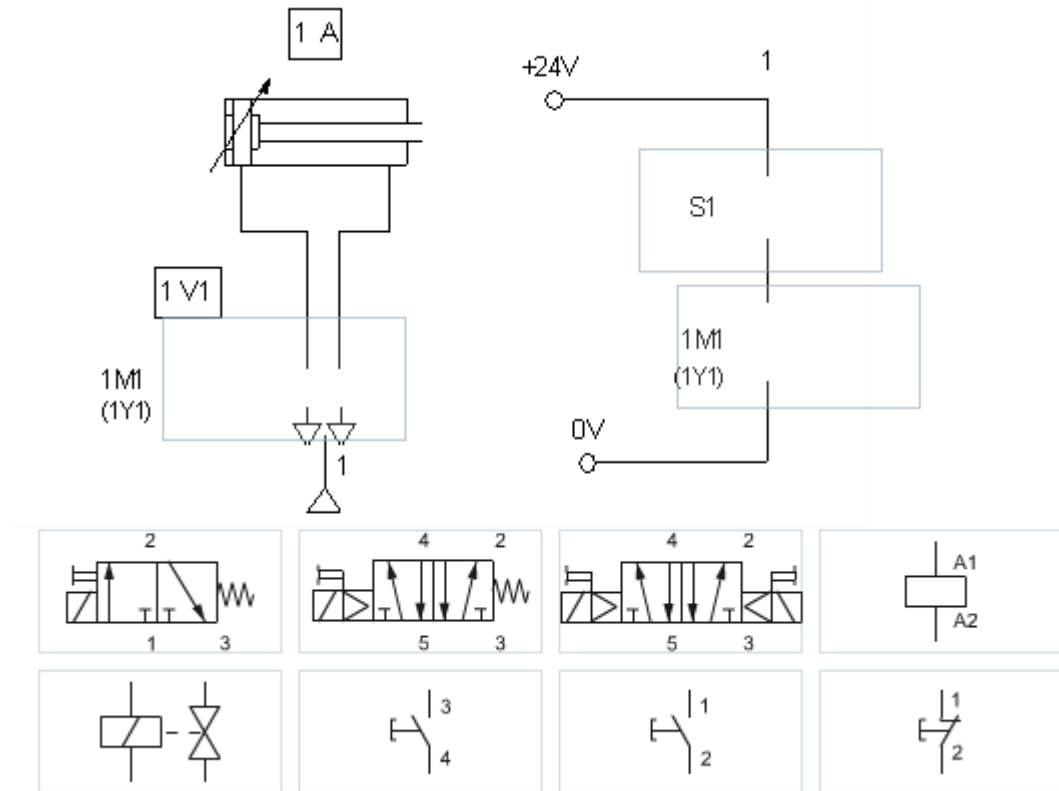

TASK-1:

Design a pneumatic circuit using double acting cylinder for the following condition.

20marks

Bulk material to be emptied from a hopper, by pressing a push button switch the hopper is opened and the bulk material is emptied out. By pressing another push button switch the hopper is closed again. Opening and closing speed to be controlled independently.

Positional Sketch:

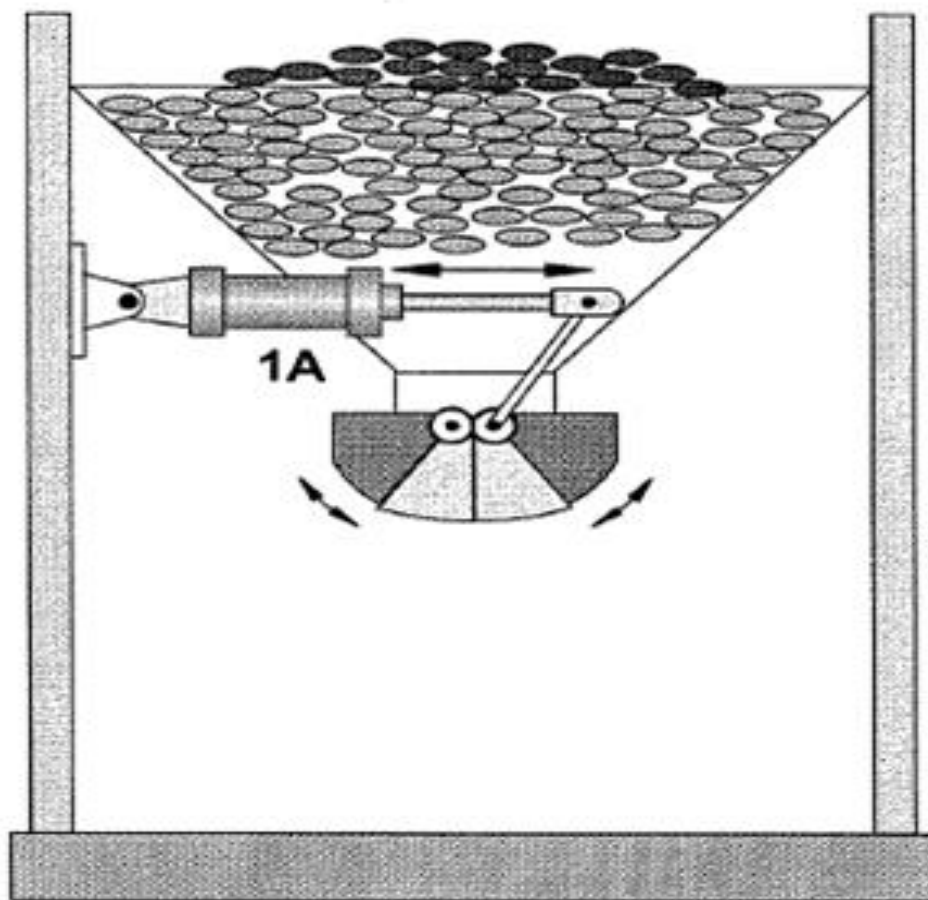

Section – C

C. Marking Scheme

Evaluation for circuit drawing - TASK1

	Circuit Drawing Total	10		
--	-----------------------	----	--	--

Practical operation evaluation criteria-TASK1

Sl.no	Operations	Marks	Score	Remarks
1	Hopper opened	2		
2	Hopper closed	2		
3	Opening speed is controlled	2		
	Operation Total	6		

Professional practice - TASK1

SI no	Criteria	Description	Marks	Score	Remarks
1	Safety	Contestant injured himself.	0.25		
2		The contestant injured another person	0.25		
3		All the pneumatic connections are connected firmly and leak free.	0.5		
4	Tools & Equipment usage	Workplace, tools and work station is free from dirt, waste and arranged neatly.	0.5		
6		Following the standard method of handling the tools	0.5		
7		No damage of tools and components	0.5		
9	Methodology	Placed the components in correct hierarchy	0.5		
10		Following proper method of plugging & unplugging of the pneumatic tubing	0.5		
11		Using the standard length of the tubes	0.5		
Professional Practice Total			4		

S.No	Description	Allotted Marks	Obtained Marks
1	Evaluation for circuit drawing	10	
2	Practical operation evaluation criteria	6	
3	Professional Practice	4	
Total Marks of Task - 1		20	

TASK-2:

Design a pneumatic and electro pneumatic circuit using the following condition.

20marks

Using a transfer station blocks are to be transferred from a magazine to a processing station.

The blocks are pushed out of the magazine by cylinder 1A and transferred to the processing station by cylinder 2A. The piston rod of cylinder 2A may only return when the piston rod of cylinder 1A has reached the retracted end position. The magazine is monitored by means of a limit switch. If there are no more blocks in the magazine, it is not possible to start the cycle. This is indicated by means of an indicator lamp. The control is to be operated in single cycle.

Positional Sketch:

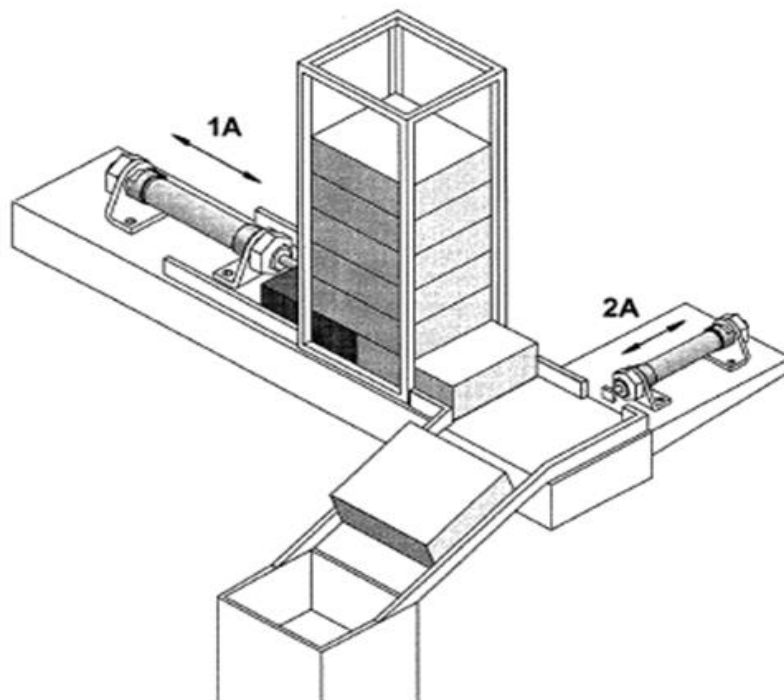

Evaluation of the circuit diagram: Task 2

Practical operation evaluation criteria-Task 2

Sl.no	Description	Marks	Score	Remarks
1	Standard symbols	2		
2	Complete circuit fulfilling all conditions	2		
3	Labeling of the circuit components	2		
4	Port markings	2		
5	Mentioning of sensors & limit switch	2		
	Circuit Drawing Total	10		

Sl.no	Operations	Marks	Score	Remarks
1	Cylinder 1A extended by push button	1		
2	Cylinder 2A extends by the activation of Sensor 1B2	1		
3	The cylinder 2A retracts only after 1A reached the retracted end position.	2		
4	Emergency stop condition	2		
	Operation Total	6		

Professional practice - Task 2

S. no	Criteria	Description	Marks	Score	Remarks
1	Safety	Contestant injured himself.	0.25		
2		The contestant injured another person	0.25		
3		All the pneumatic connections are connected firmly and leak free.	0.5		
4	Tools & Equipment usage	Workplace, tools and work station is free from dirt, waste and arranged neatly.	0.5		
6		Following the standard method of handling the tools	0.5		
7		No damage of tools and components	0.5		
9	Methodology	Placed the components in correct hierarchy	0.5		
10		Following proper method of plugging & unplugging of the pneumatic tubing	0.25		
11		Using the proper colour of the wire	0.25		
12		Using the standard length of the tubes	0.5		
Professional Practice Total			4		

Task 2 Tabulation

S.No	Description	Allotted Marks	Obtained Marks
1	Evaluation for circuit drawing	10	
2	Practical operation evaluation criteria	6	
3	Professional Practice	4	
Total Marks of Task - 2		20	

TASK-3:

Design a pneumatic and electro pneumatic circuit using the following condition.

20 Marks

A stamping device can be operated from three sides. A workpiece is inserted via guide, whereby it touches two of the three proximity switches B1, B2 and B3. This causes the pneumatic cylinder 1.0 to extend via a solenoid valve (coil Y1), whereby a recess is to be stamped into the workpiece. The stamping cycle is to be triggered only if two signal generators are addressed. For a reason of safety, the cylinder must be prevented from advancing, if all three proximity sensors are contacted.

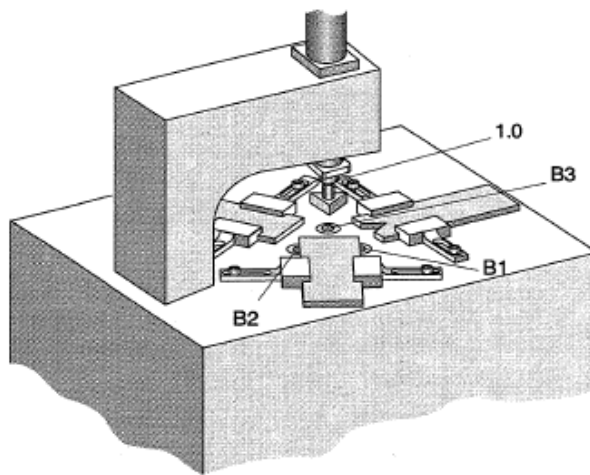

Drawing up the electrical circuit diagram.

Complete the electrical circuit diagram and enter the input and output addresses available for your PLC.

6 Marks

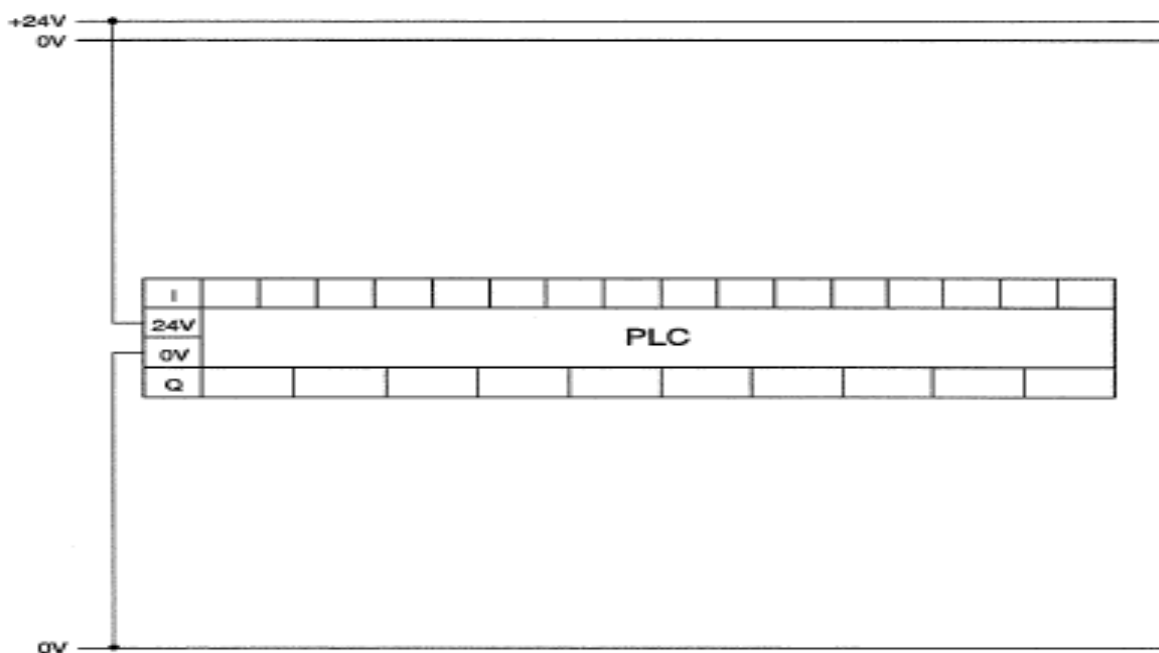

Declaring of variables required in your PLC program:

4 Marks

Designation	Data type	Address	Comment

Testing and commissioning of the PLC program and the system:

6 Marks

Switch off the pneumatic system and electrical supply remains ON, connect the PLC in online mode.

S.No	Operations	Marks	Score	Remarks
1	Force the sensor B1 its corresponding bit address to be high	1		
2	Force the sensor B2 its corresponding bit address to be high	1		
3	Force the sensor B3 its corresponding bit address to be high	1		
4	The stamping solenoid to be triggered only with two sensors ON	2		
5	If all the three sensors are high then the stamping cycle is not triggered.	1		
	Operation Total	6		

Sl no	Criteria	Description	Marks	Score	Remarks
1	Safety	Contestant injured himself.	0.25		
2		The contestant injured another person	0.25		
3		All the pneumatic connections are connected firmly and leak free.	0.5		
4	Tools & Equipment usage	Workplace, tools and work station is free from dirt, waste and arranged neatly.	0.5		
6		Following the standard method of handling the tools	0.5		
7		No damage of tools and components	0.5		
9	Methodology	Placed the components in correct hierarchy	0.5		
10		Following proper method of plugging & unplugging of the pneumatic tubing	0.25		
11		Using the proper colour of the wire	0.25		
12		Using the standard length of the tubes	0.5		
Professional Practice Total			4		

Task 3 Tabulation

S. No	Description	Allotted Marks	Obtained Marks
1	Drawing up the electrical circuit diagram.	6	
2	Declaring of variables required in your PLC program:	4	
2	Testing and commissioning of the PLC program and the system	6	
3	Professional Practice	4	
Total Marks of Task - 2		20	

Section - D

D. Infrastructure List

- Workshop Installation-Tools & Equipment positioned by Organizers

(list is for 1 competitor) Basic Pneumatic components*

- 1 2x 3/2-way valve with pushbutton actuator, normally closed
- 2 1x 3/2-way valve with pushbutton actuator, normally open
- 3 1x 5/2-way valve with selector switch
- 4 1x 3/2-way valve with selector switch, normally closed
- 5 2x 3/2-way roller lever valve, normally closed
- 6 2x Proximity sensor, pneumatic, with cylinder attachment
- 7 1x Pneumatic timer, normally closed
- 8 1x Pressure sequence valve
- 9 1x 3/2-way valve, pneumatically actuated at one end
- 10 1x 5/2-way valve, pneumatically actuated at one end
- 11 3x 5/2-way double pilot valve, pneumatically actuated at both ends
- 12 1x Shuttle valve (OR)
- 13 2x Dual-pressure valve (AND)
- 14 1x Quick-exhaust valve
- 15 2x One-way flow control valve
- 16 1x Single-acting cylinder
- 17 1x Double-acting cylinder
- 18 1x Start-up valve with filter control valve
- 19 1x Pressure regulator valve with gauge
- 20 2x Pressure gauge
- 21 1x Manifold
- 22 2x Plastic tubing, 4 x 0.75 silver 10 m

Electro Pneumatic components

Complete equipment set TP 201

- 1 1x Signal input, electrical
- 2 2x Relay, three-fold
- 3 1x Limit switch, electrical, left-actuated
- 4 1x Limit switch, electrical, right-actuated
- 5 1x Proximity sensor, optical, M12
- 6 2x Proximity sensor, electronic, with cylinder mounting
- 7 1x 2 x 3/2-way solenoid valve with LED, normally closed
- 8 1x 5/2-way solenoid valve with LED
- 9 2x 5/2-way double solenoid valve with LED
- 10 1x Pressure sensor with display
- 11 4x One-way flow control valve
- 12 1x Single-acting cylinder
- 13 2x Double-acting cylinder
- 14 1x Start-up valve with filter control valve
- 15 1x Manifold
- 16 1x Plastic tubing, 4 x 0.75 silver 10 m

Complete supplementary equipment set TP 101 – TP 201

- 1 1x Signal input, electrical
- 2 2x Relay, three-fold
- 3 1x Limit switch, electrical, left-actuated
- 4 1x Limit switch, electrical, right-actuated
- 5 1x Proximity sensor, optical, M12
- 6 2x Proximity sensor, electronic, with cylinder mounting
- 7 1x 2 x 3/2-way solenoid valve with LED, normally closed
- 8 1x 5/2-way solenoid valve with LED
- 9 2x 5/2-way double solenoid valve with LED
- 10 1x Pressure sensor with display
- 11 2x One-way flow control valve
- 13 1x Double-acting cylinder

Festo Basic Pneumatic system equipment set TP 101

Festo Basic Electro Pneumatic training equipment set TP 201

Junior compressor

Pneumatic work table with aluminium profile.

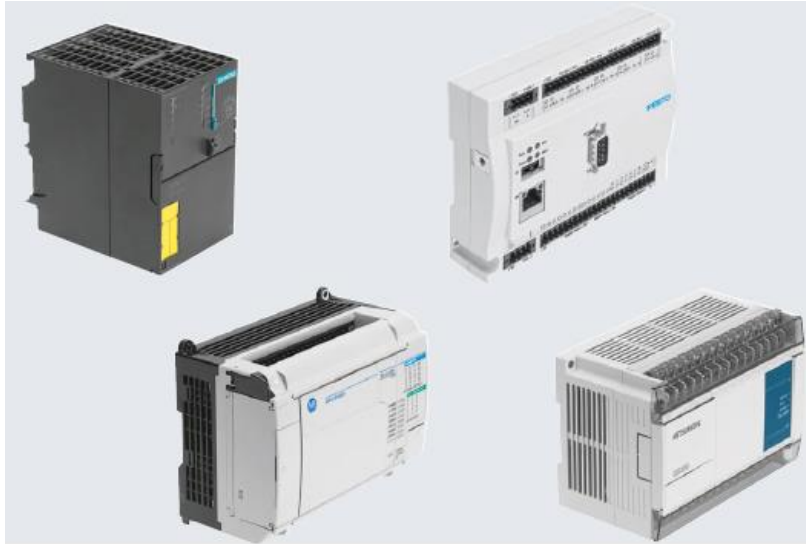

This EduTrainer® is universal because it can be fitted with all industrial controllers from the market leaders:

- Siemens S7
- Siemens LOGO!
- Festo CECC
- Festo CPX
- Allen-Bradley
- Mitsubishi
- and more

Tool Kit-Tool & Equipment allowed to be brought by competitors for competitions

- Screw driver
- Tester
- Crimping tool
- Lugging tool
- Nose plier
- Multimeter

*** Festo or Equivalent made (all above listed)**

Section – E

E. Instructions for candidates

- Competitors have to complete writing circuit within the time of first session
- Competitors have to connect the same circuit has written by them in answer paper, change in circuit with lead for reduction in points
- During practical session change in the written circuit is not allowed
- Time will be allocated to check the working condition of the component, declaration on not working condition should be done that time
- The working methodologies are considered for marking
- Any damage in the component will not be replaced if declared after starting of the competition
- Competitors can check for the working of the circuit any number of time before declaration
- If found short circuit in the circuit during evaluation, the evaluation will be stopped.

Section – F

F. Health, Safety, and Environment

1. All accredited participants, and supporting volunteers will abide by rules and regulations with regards to Health, Safety, and Environment of the Competition venue.
2. All participants, technicians and supporting staff will wear the required protective Personnel clothing.
3. All participants will assume liability for all risks of injury and damage to property, loss of property, which might be associated with or result from participation in the event. The organizers will not be liable for any damage, however in case of Injury the competitor will immediately inform the immediate organizer for medical attention.